

COP Technical Data

Low Level Order Picker

COP 20

COP-H 10

COP-L 07



In accordance with VDI guidelines 2198 and 3597, respectively, this specification applies to the standard model only. Alternative tyres, mast types, ancillary equipment, etc. may result in different values.

				STILL				STILL					
				COP 20 Fixed platform with tray 53	COP 20 Lifting platform with tray 53	COP 20 Lifting platform with tray 54	COP 20 Lifting platform with tray 54	COP-H 10 Fixed platform	COP-H 10 Lifting platform	COP-L 07 Without auxiliary lift/fixed forks	COP-L 07 With auxiliary lift/ fixed forks	COP-L 07 With auxiliary lift/ adjustable forks	
Characteristics	1.1	Manufacturer											
	1.2	Manufacturer's model designation											
	1.3	Drive		Electric	Electric	Electric	Electric	Electric	Electric	Electric	Electric	Electric	
	1.4	Control		Stand-on	Stand-on	Stand-on	Stand-on	Stand-on	Stand-on	Stand-on	Stand-on	Stand-on	
	1.5	Rated capacity/load	Q	kg	2000	2000	2000	1000	1000	700	700	700	
	1.6	Load centre distance	c	mm	1200	1200	1200	600	600	600	600	600	
	1.8	Load centre	x	mm	1487	1487	1487	857	857	105	100	140	
	1.9	Wheel base	y	mm	2576	2661	2661	2062	2062	1210	1210	1210	
	Weights	2.1	Weight (incl. battery)		kg	1141	1210	1254	1323	1169	1239	1193	1297
2.2		Axle load with load	drive end/load end	kg	1107/2034 ¹	1162/2048 ¹	1186/2068	1239/2084	989/1180 ¹	1041/1198 ¹	417/1476 ¹	409/1588 ¹	374/1656 ¹
2.3		Axle load without load	drive end/load end	kg	885/256 ¹	940/270 ¹	970/284	1023/300	864/305 ¹	916/323 ¹	821/372 ¹	813/484 ¹	804/526 ¹
Wheels / Tyres	3.1	Tyres			Polyurethane	Polyurethane	Polyurethane	Polyurethane	Polyurethane	Polyurethane	Polyurethane	Polyurethane	
	3.2	Tyre size	drive end	mm	∅ 250 x 80	∅ 250 x 80	∅ 250 x 80	∅ 250 x 80	∅ 250 x 80	∅ 250 x 80	∅ 250 x 80	∅ 250 x 80	
	3.3	Tyre size	load end	mm	∅ 85 x 70	∅ 85 x 70	∅ 85 x 70	∅ 85 x 70	∅ 85 x 90	∅ 85 x 90	∅ 120 x 50	∅ 120 x 50	
	3.4	Castor wheels		mm	∅ 110 x 60	∅ 110 x 60	∅ 110 x 60	∅ 110 x 60	∅ 110 x 60	-	-	-	
	3.5	Wheels, number (x = driven)	drive end/load end		1x -2/4	1x -2/4	1x -2/4	1x -2/4	1x -2/2	1x -2/2	1x/4	1x/4	
	3.6	Track width	drive end	b ₁₀	mm	558	558	558	558	558	-	-	
	3.7	Track width	load end	b ₁₁	mm	318 / 358 / 488	318 / 358 / 488	318 / 358 / 488	318 / 358 / 488	370	370	780	
Dimensions	4.2	Closed mast height		h ₁	mm	-	-	-	-	-	-	1577	
	4.4	Lift		h ₃	mm	125	125	125	745	745	745	1040	
	4.5	Height platform raised		h ₄	mm	-	2053	-	2053	-	2053	2343	
	4.8	Height seat/stand-on (platform)		h ₇	mm	112	148	112	148	112	148	160	
	4.9	Tiller height in driving position	min./max.	h ₁₄	mm	1212	1212	1212	1212	1212	1212	1245	
	4.11	Auxiliary fork lift		h ₉	mm	-	-	-	-	-	674	712	
	4.14	Stand-on height, raised		h ₁₂	mm	-	900	-	900	-	900	1200	
	4.14.1	Picking height (h ₁₂ +1600)		h ₂₈	mm	-	2500	-	2500	-	2500	2800	
	4.15	Height, lowered		h ₁₃	mm	85	85	85	85	85	85	45	
	4.19	Overall length without load		l ₁	mm	3672	3757	3757	2538	2648	2643	2683	
	4.20	Length incl. fork face		l ₂	mm	1272	1357	1357	1388	1498	1493	1533	
	4.21	Overall width		b ₁	mm	805	805	805	805	805	810	810	
	4.22	Fork dimensions		s/e/l	mm	60/182/2400	60/182/2400	60/182/2400	55/170/1150	50/160/1150	55/160/1150	35/100/1150	
	4.25	External fork width		b ₅	mm	520/540/670	520/540/670	520/540/670	540	540	540	300-680	
	4.32	Floor clearance with load beneath mast		m ₂	mm	45	45	45	45	45	45	45	
4.34	Working aisle width at pallet dim. 800 x 1200 lengthwise (b ₁₂ x l ₆)		A _{st}	mm	3956 ²	4041 ²	4041 ²	2972	2960	2955	2993		
4.34.1	Working aisle width at pallet dim. 1000 x 1200 crossways (l ₆ x b ₁₂)		A _{st}	mm	-	-	-	3062	2852	2848	2883		
4.35	Turning radius		W _a	mm	2759 ²	2844 ²	2844 ²	2245	2245	2245	1395		
Performance	5.1	Travelling speed	with/without load	km/h	11/14	11/14	11/14	11/14	11/14	8,5/8,5	8,5/8,5		
	5.1.1	Travelling speed backwards	with/without load	km/h	7/7	7/7	7/7	7/7	7/7	7/7	7/7		
	5.2	Lifting speed	with/without load	m/s	0.04/0.05	0.11/0.21	0.04/0.05	0.11/0.21	0.09/0.11	0.2/0.38	0.18/0.26		
	5.3	Lowering speed	with/without load	m/s	0.05/-	0.05/-	0.05/-	0.1/-	0.1/-	0.1/-	0.24/0.24		
	5.7	Climbing capacity	with/without load	%	6/6 ³	6/6 ³	6/6 ³	6/6 ³	6/6 ³	6/6 ³	6/6 ³		
	5.10	Service brake				Electromagnetic	Electromagnetic	Electromagnetic	Electromagnetic	Electromagnetic	Electromagnetic		
Electric motor	6.1	Drive motor, capacity S2 = 60 min		kW	3	3	3	3	3	3	3		
	6.2	Lift motor, capacity at S3 = 15%		kW	1.2	1.4	1.2	1.4	1.2	1.4	2.2		
	6.3	Battery in accordance with DIN 43531/35/36; A, B, C, no			No	No	No	No	No	No	No		
	6.4	Battery voltage, nominal capacity K _s		V/Ah	24/345-465	24/560-620	24/560-620	24/420-465	24/420-465	24/420-465	24/420-465		
	6.5	Battery weight ±5% (depending on manufacturer)		kg	402	515	515	390	390	390	390		
Other	8.1	Type of drive control			AC control	AC control	AC control	AC control	AC control	AC control	AC control		
	8.4	Noise level, driver's ear		dB(A)	<70	<70	<70	<70	<70	<70	<70		

¹ Weight without operator.

² Lowered forks increase the dimension by 83 mm.

³ Climbing capacity based on truck geometry.

Fork dimensions COP 20

(All values given in mm)

l	c	y ^{1,2}	l ₁ ¹	W _a ^{1,2}	x ²	A _{st} ^{1,2,3}
1150	600	1980	2422	2162	891	2867
1450	750	2150	2722	2333	1061	3127
2160	1100	2561	3432	2744	1472	3775
2400	1200	2576	3672	2759	1487	3956
2400	1200	2849	3672	3032	1760	3987
2850	1450	2939	4122	3122	1850	4446

¹ Tray 54 increases the dimension by 85 mm.

² Lowered forks increase the dimension by 83 mm.

³ Working aisle width with load carrier 800 x 1 200 mm (lengthways) with forks raised.

COP-H 10

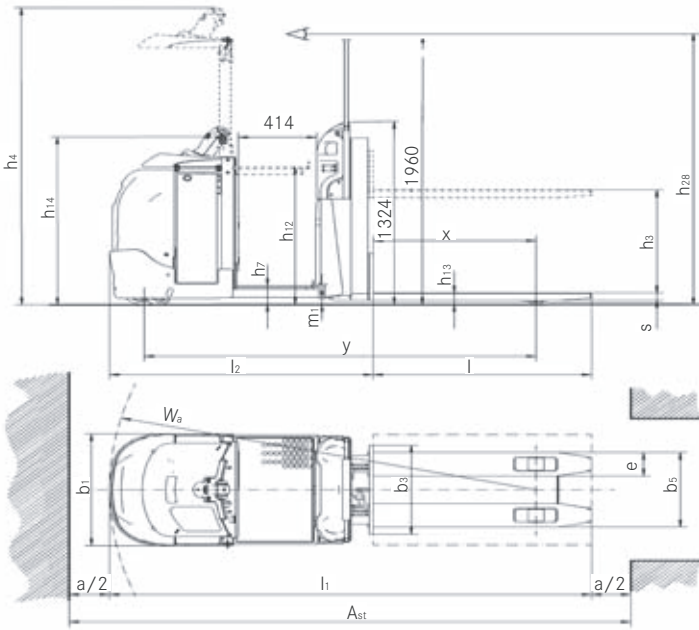

COP-L 07

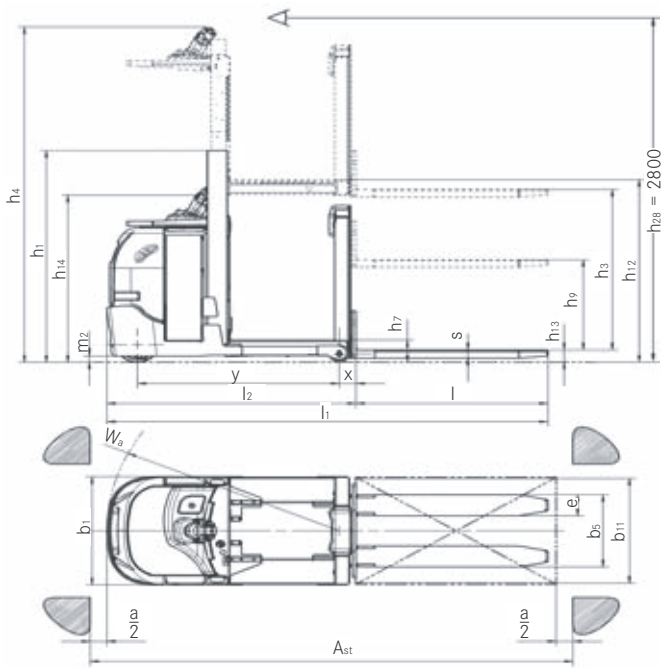

COP 20

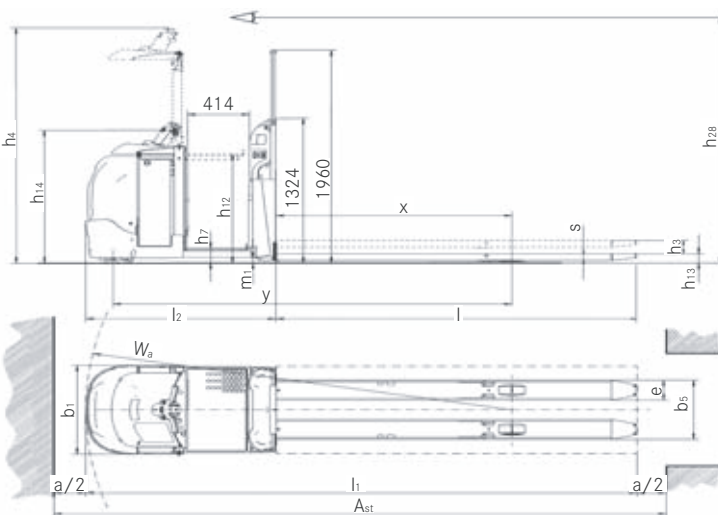

The order pickers of the COP series combine high agility for narrow warehouses with excellent driving dynamics and high productivity also when order picking at first and second level.

Truck frame

The special drive concept of the COP series was derived from the low lift trucks with a centrally situated drive wheel and strong lateral castor wheels offering perfect traction. This allows the COP to travel at high speeds also when cornering and easily trespass ramps and transitions.

- Its rugged covers are made from resilient plastic that withstand even strong impacts without permanently deforming or breaking.
- The patented initial lift mechanism makes the truck very short providing an outstandingly small turning radius and high manoeuvrability.

Steering

- By standard the COP is equipped with an electric steering system.
- Multi-function cockpit to operate all functions for lifting and driving.
 - Automatic curve speed reduction.

Driver's compartment

The stand-on platform for the driver provides a large space covered with a soft, anti-slip rubber mat at low access height to make mounting and leaving the truck easy and comfortable.

- The ergonomically shaped rear wall offers the driver a comfortable and safe ride also when travelling fast.
- The driver's compartment offers numerous deposit trays for tools and documents.

Platform lift (option)

To accelerate order picking at higher levels, the COP 20 and COP-H 10 models are available with an optional 900 mm platform lift.

- Simultaneous lifting of the platform and driving as well as the possibility to lower the platform by depressing a foot switch allows maximum turnover performance.
- 170 kg lift capacity and the well dimensioned deposit space in front of the cockpit make the lift platform an indispensable equipment for every day operation and excellent order picking performance.
- The driving speed is automatically adjusted to the current lift height.

Drive

The 3-kW AC drives ensure:

- high driving dynamics.
- low drive noise.
- energy recuperation to reduce energy consumption.
- no maintenance.

Battery

The 24-V battery facilitates easy access and can be exchanged for multi-shift operation by crane or optionally over the side by the integrated roller track.

The battery tray provides a capacity for batteries up to 620 Ah.

Brake

The COP series is equipped with three brake systems:

- Parking and emergency brake
 - Emergency brake: electro-magnetic brake closing at each full stop or at depressing the emergency stop button.
- Electric brake: the truck brakes electrically when the driver releases the accelerator switch. During braking, the AC motor functions as a generator and feeds the recuperated energy back into the battery.
- Service brake: combined braking. An innovative system combining the motor brake and the electro-magnetic brake by the patented electronic "eABS" module. The brake closes on release of the "dead man switch" and on releasing the inching button. This system allows efficient braking without blocking the wheels.

Stability system

The patented castor wheels provide optimum lateral stability when travelling with load as well as when travelling without load. The stability system "IntelliDrive" bases on the combined effectiveness of spiral and pneumatic springs to provide optimum stability in all conditions.

Options

- Buttons for pedestrian operation in the backrest.
- Additional front bumper.
- Additional paper clip.
- Electric preparation for data terminal.
- Cold store version.

COP-L 07

The compact and agile COP-L 07 with a stand-on height up to 1200 mm is the perfect choice for order picking at the first and second level.

On request this truck is also available with ergonomic auxiliary lift or adjustable forks.



Workplace of the COP 20 and COP-H 10

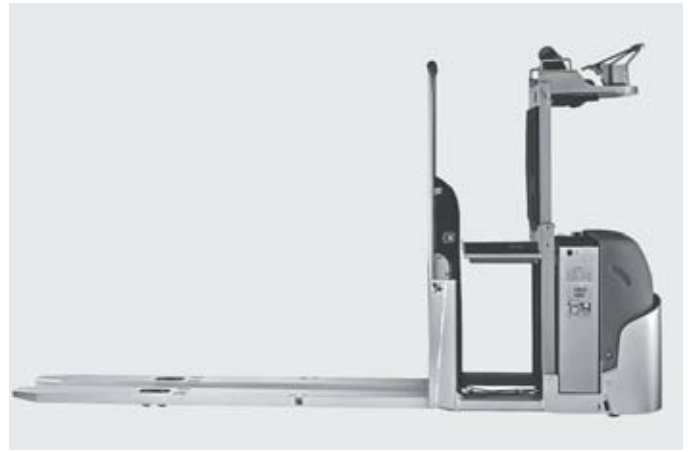

Telescopic stand-on platform for first level order picking

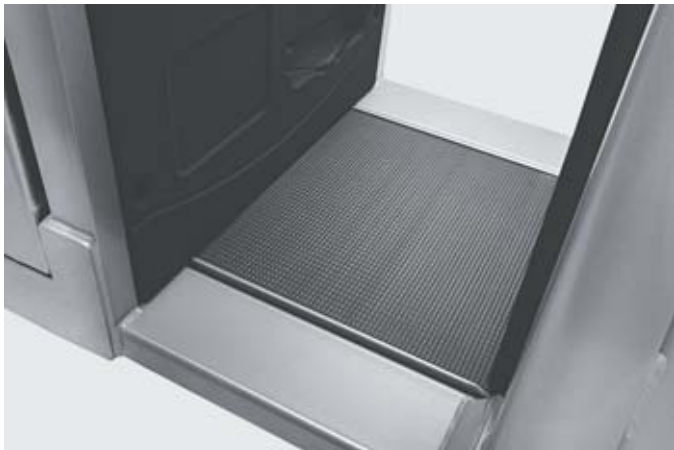

Low access and non-slip stand-on area



Collision guard for the COP 20 and COP-H 10



Optional auxiliary lift for the COP-L 07



Safe two-hand operation of the auxiliary lift in the COP-L 07



COP 20



Smart Forxx SIA



Contact us

If you have any questions or if you want more information we are at your disposal.

61 Matisa, Apt. 24
Riga LV-1009
Latvia

Sales department:

Tel.: +371 29 507 102

Service department:

Tel.: +371 29 632 267

E-mail:

info@smartforxx.lv

Online services:

www.smartforxx.lv